

Product leaflet

Product
Compressed air filter

Model No.
SR 99

Ordering No.
H03-2612

Product Description

The SR 99 compressed air filter is used for producing clean breathing air from ordinary compressed air. The unit consists of a regulator (C), pre-collector (D) and main filter (SR 292), all of which are mounted in an enclosing steel sheet stand. The unit can be placed on the floor or mounted on a wall. The pre-filter, which has a pressure-controlled/manual drain, collects coarse particles, water and oil. The SR 292 main filter consists of a carbon filter part (500g), surrounded by two P3 particulate filters. The air is cleaned to remove any remaining particles/gases/vapours/odours. A Y coupling that increases the number of outlets is available as accessory.

Technical specification

SR 99	
Inlet connection	1/2" BSP
Inlet pressure	6–10 bar
Outlet connections	One safety coupling and one plugged opening
Air flow	Maximum 900 l/min - three users
Filter area P3	≈ 2 200 cm ²
Activated carbon	≈ 500 grams
Adsorption capacity	≈ 100–150 grams oil.

- A. Pressure gauge
- B. Inlet
- C. Regulating valve
- D. Pre-collector
- E. Drain
- F. Outlet
- G. Particle filter
- H. Activated carbon

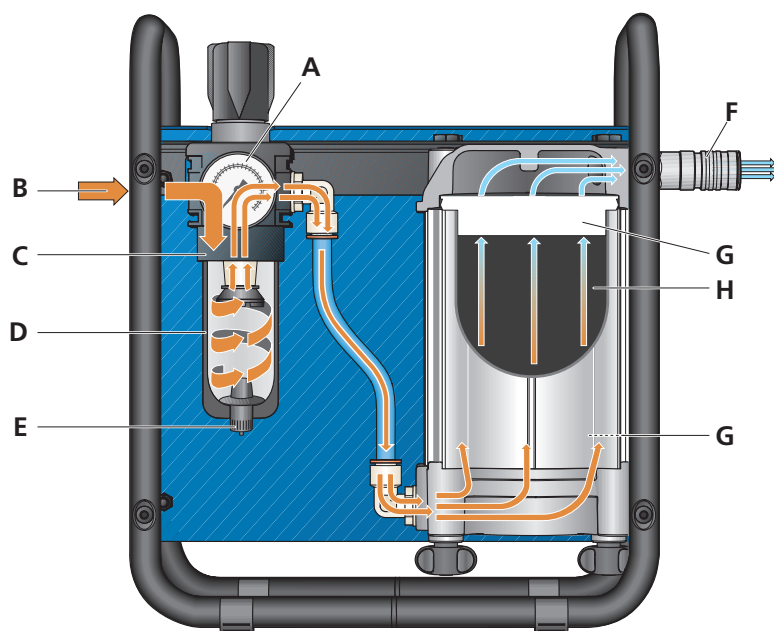

Head Office

Tel: +46-(0)8-562 370 00
 Fax: +46-(0)8-562 370 20
 P.O. Box 10056
 SE-181 10 Lidingö
 Sweden
 Visiting address:
 Vasavägen 84
 SE-181 10 Lidingö

Factory

Tel: +46-(0)8-562 370 00
 Fax: +46-(0)8-562 370 60
 P.O. Box 76
 SE-340 14 Lagan
 Sweden
 Visiting address:
 Västergatan 4
 SE-340 14 Lagan

Sundström 
www.srsafety.com